

CABLAGGIO WIRING

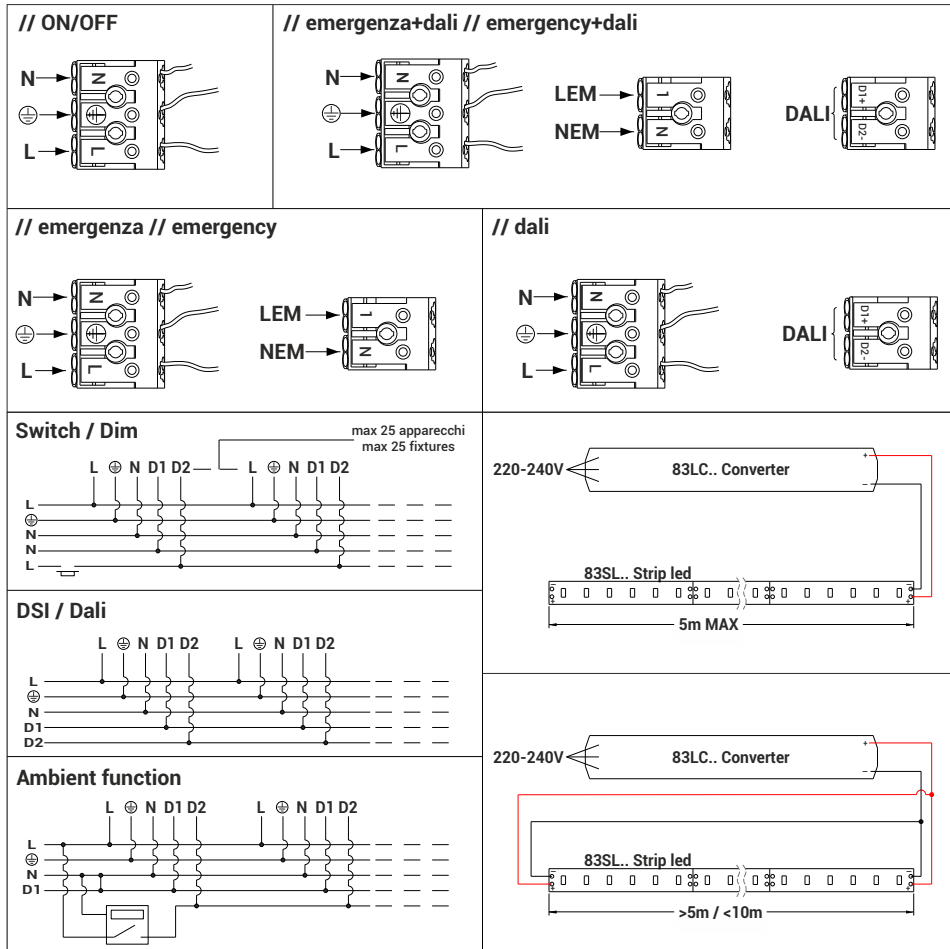

// Avvertenze. La sicurezza dell'apparecchio è garantita solamente con l'uso appropriato delle presenti istruzioni che devono essere lette e conservate. • Togliere tensione di rete prima della sostituzione delle lampade e comunque prima di ogni operazione di manutenzione. • Non coprire l'apparecchio con panni o con quant'altro possa causare un eccessivo surriscaldamento. • La nostra azienda declina ogni responsabilità per danni causati da uno scorretto utilizzo o dalla manomissione dell'apparecchio stesso. • Per la sostituzione di componenti usurati rivolgersi a personale qualificato. • L'apparecchio non deve essere smaltito come rifiuto urbano. Deve essere soggetto a raccolta separata per evitare danni all'ambiente nel rispetto della direttiva 2002/96 e delle leggi nazionali per lo smaltimento del prodotto a fine vita. Il mancato rispetto di quanto sopra è sanzionato dalla Legge. • Si prega di informarsi in merito al sistema locale di raccolta differenziata per i prodotti elettrici ed elettronici.

// Warning. The safety of the fixture is guaranteed only under the correct use of the present instructions, which have to be read and kept. • Turn off the net voltage before the replacement of the lamp and however before any maintenance action. • Do not cover the fixture with clothes or something else which could cause an excessive overheating. • Our company declines all responsibility for damages caused by an incorrect use or by the tampering of fixture itself. • For replacement of worn out components please address to the skilled staff. • The fixture could not be disposed as urban waste. It must be subject o separate waste collection to avoid environmental damage in compliance with directive 2002/96 and national laws for the disposal of product at the end of its working life. The non-compliance of the above mentioned directive will be sanctioned by Law. • We ask you to kindly get information about local separate waste collection system for electric and electronic products.

ISND

ENDO

// Istruzioni per il montaggio // Assembly instructions

- Emissione diretta/indiretta
Direct / Indirect emission
- UGR<22; <16
- IP40, IP65
- 2700K/3000K/3500K/4000K
5000K / TW / RGBW / DTW
- >100lm/W
- CRI>90
- Eye safety: RGO/RG1
- Mac Adams 3
- L80/B10>50.000h
- EEA Conformity
- Energy class
- 5 years warranty

ATTENZIONE! Rischio fotobiologico: gruppo di rischio 1
CAUTION! Photobiological safety: risk group 1

MADE IN ITALY

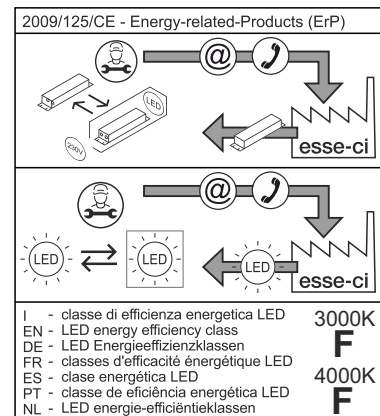

Attenzione: questo foglio contiene informazioni e suggerimenti importanti. Si prega di leggerlo per intero prima di procedere con l'installazione degli apparecchi.

Attention: this paper contains important info and tips. Please read the full paper before to proceed with installation.



Attenzione: prima di procedere con ciascuna delle seguenti operazioni, togliere la tensione di rete ed utilizzare i guanti in dotazione.

Attention: before proceeding with each of the following operations, switch off the power supply at the consumer unit. Use the gloves supplied.

ENDO installazione e montaggio strip mounting & strip installation

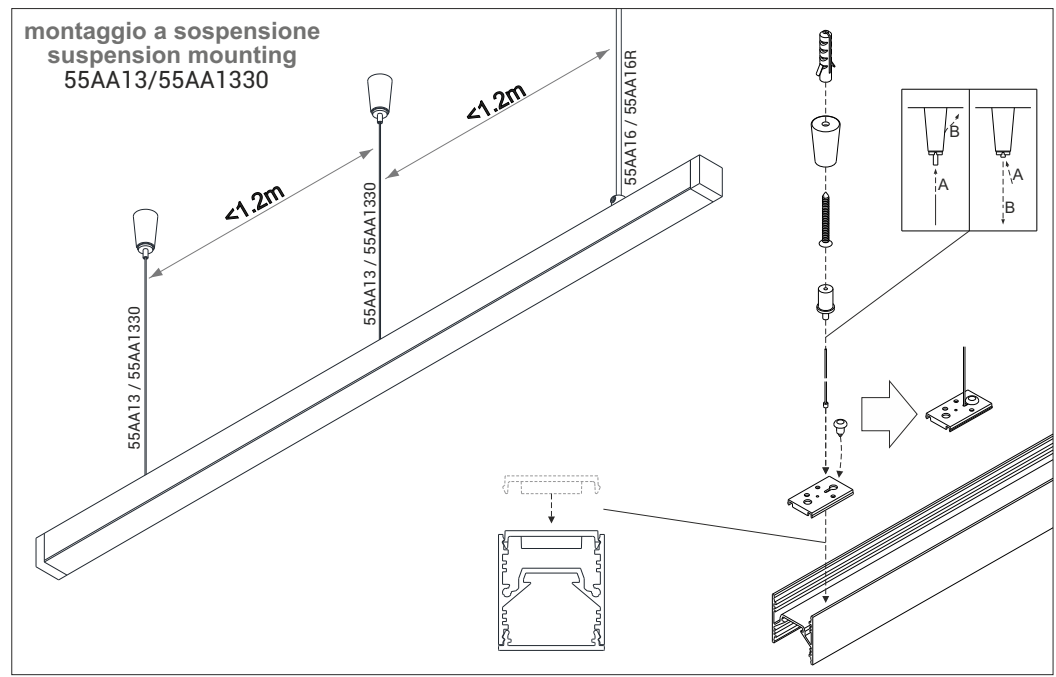
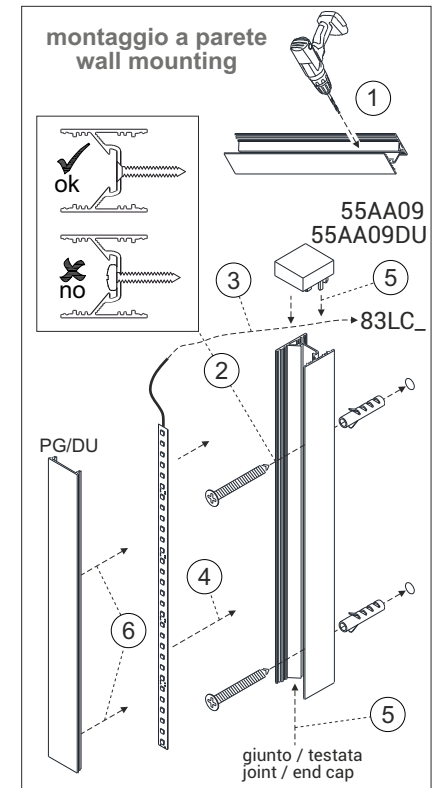
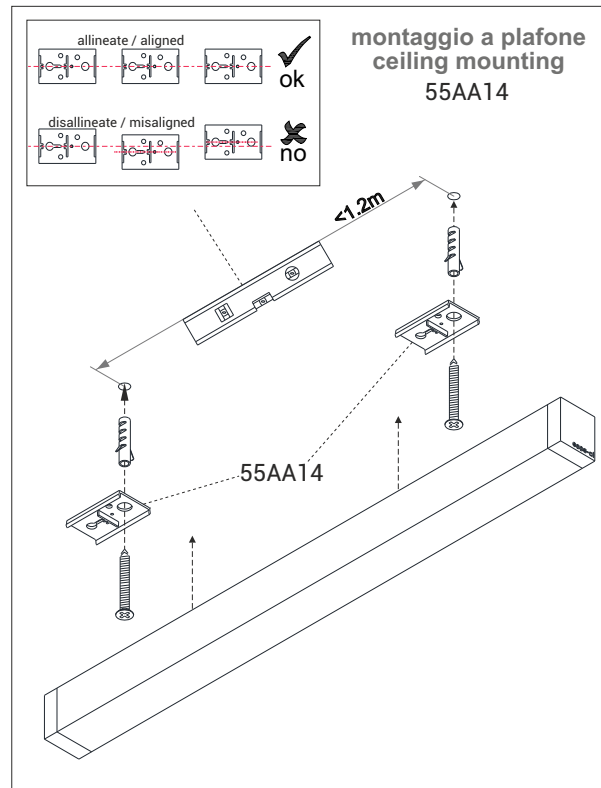
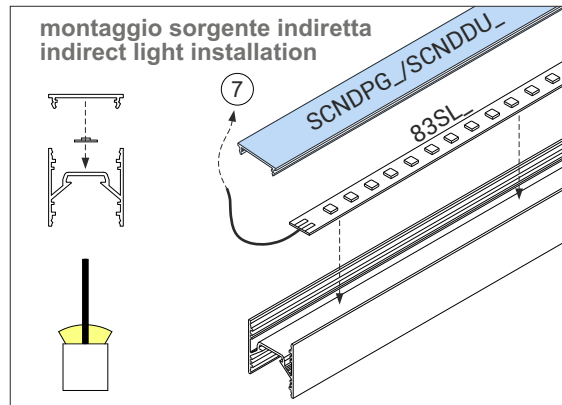
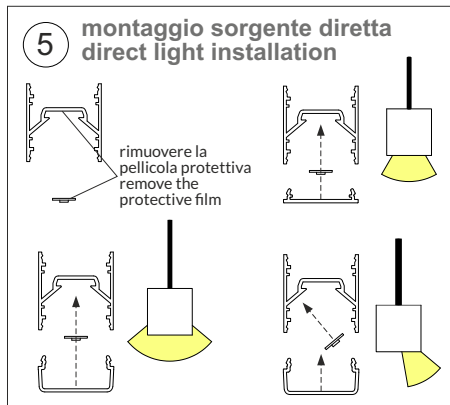
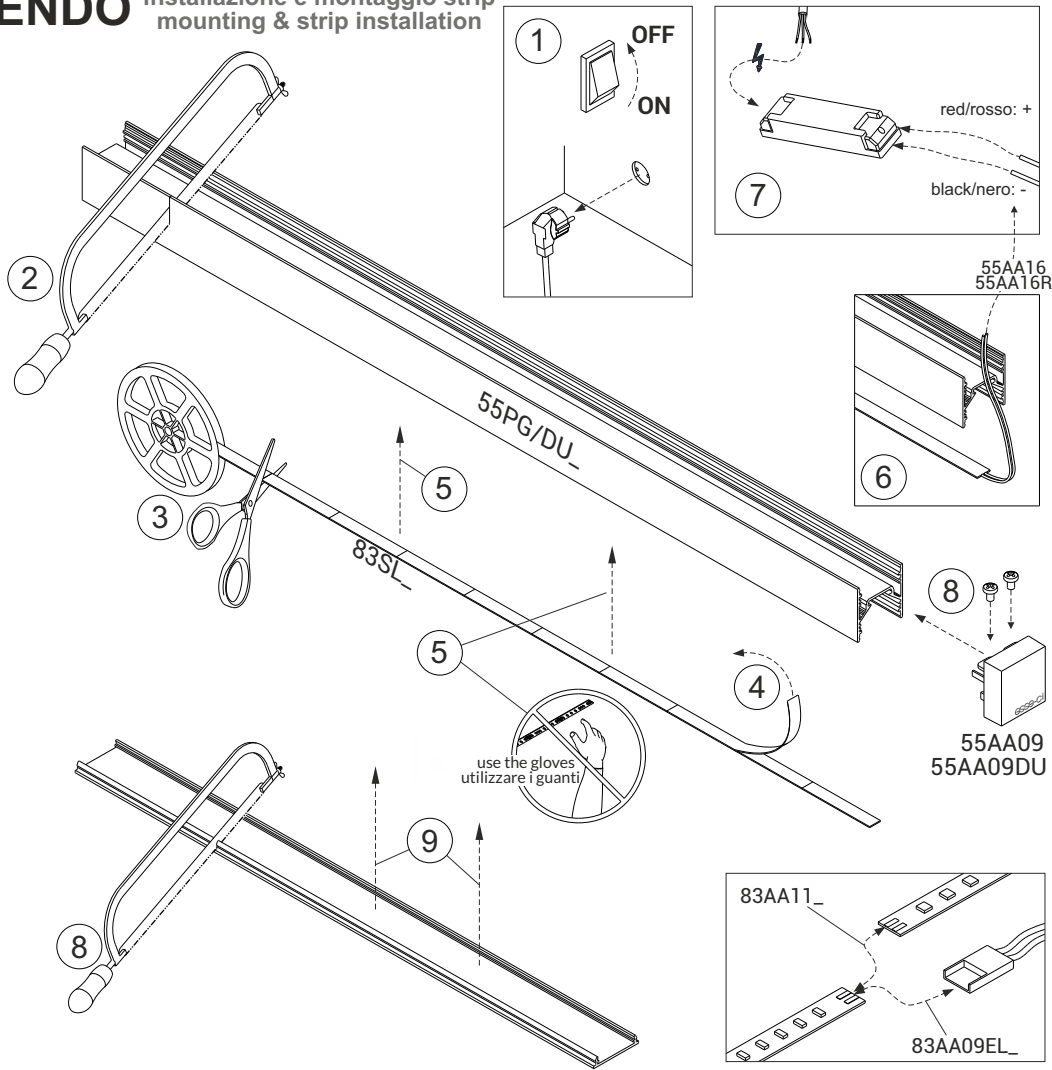

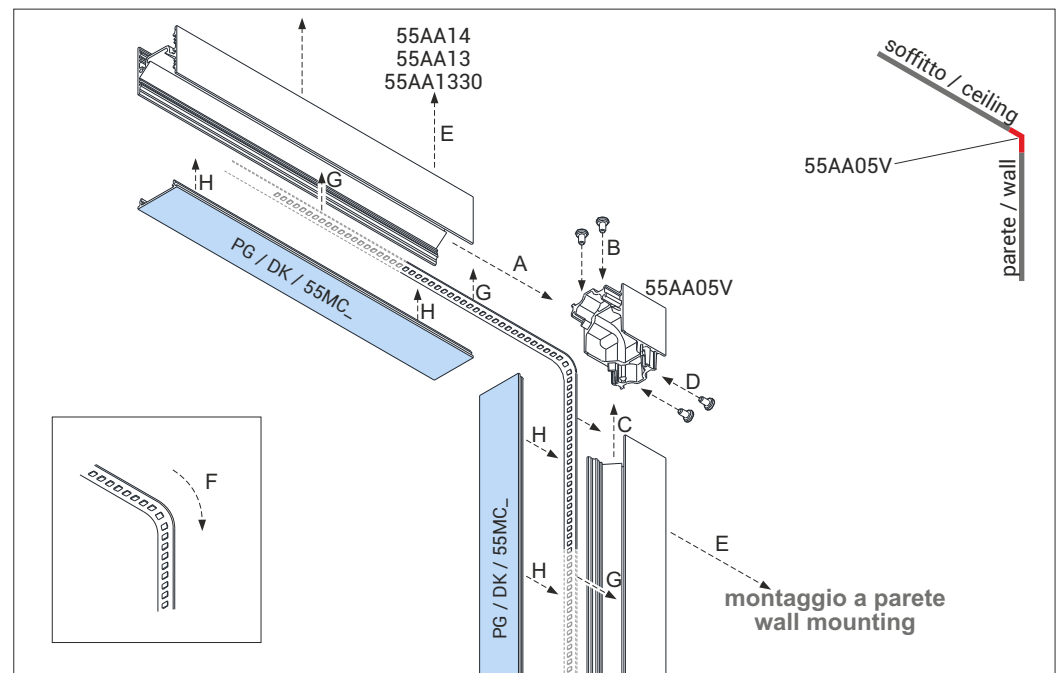
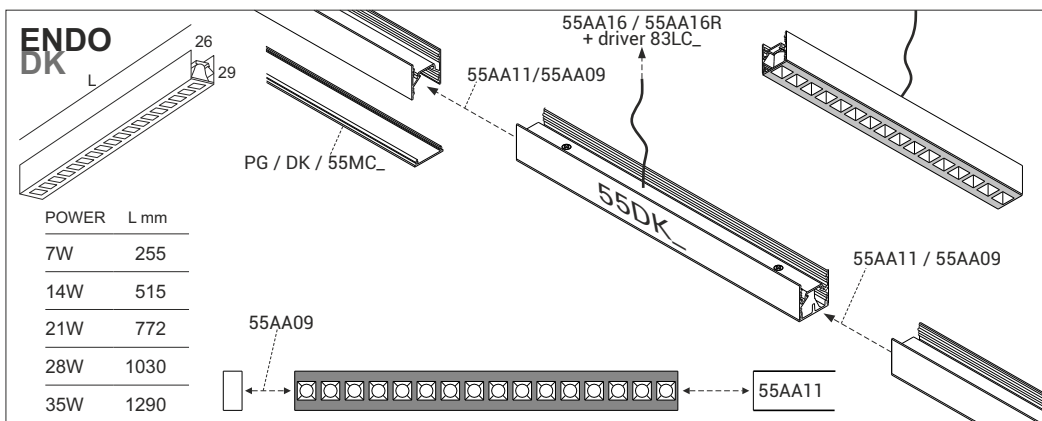
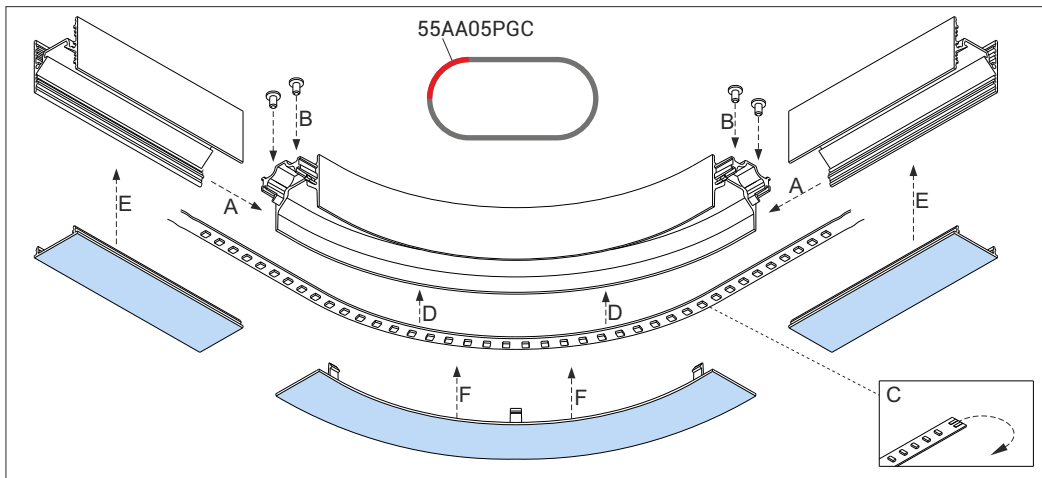
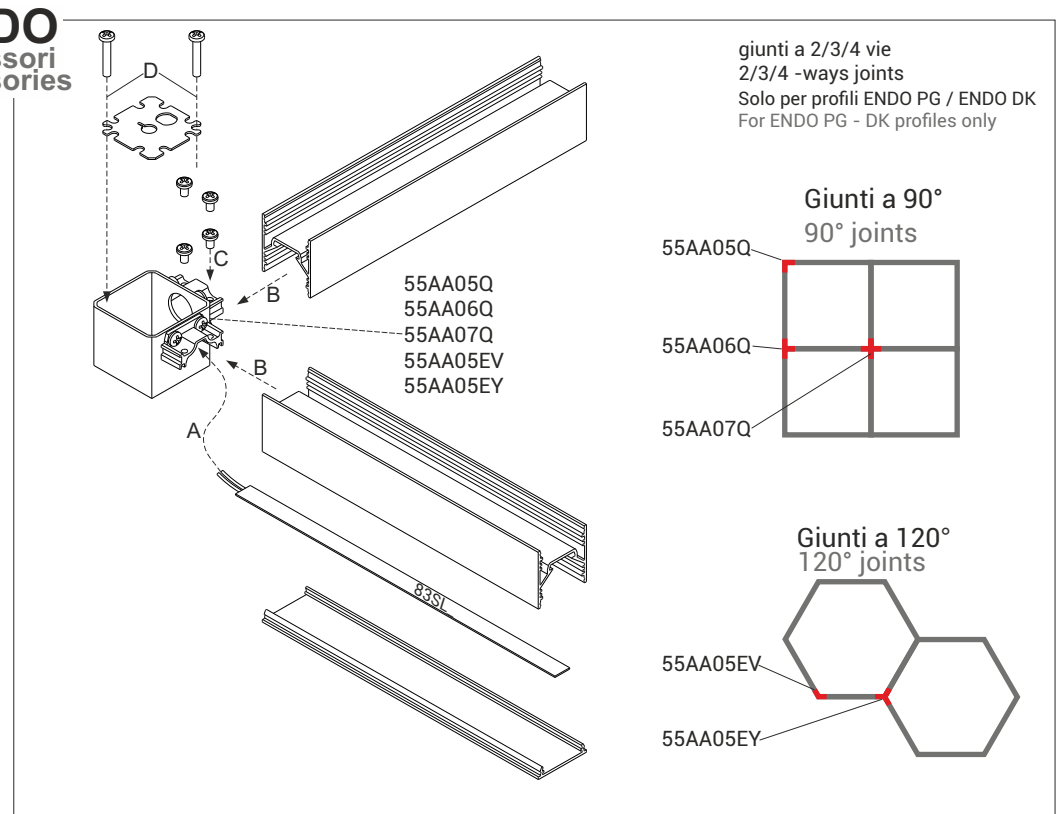
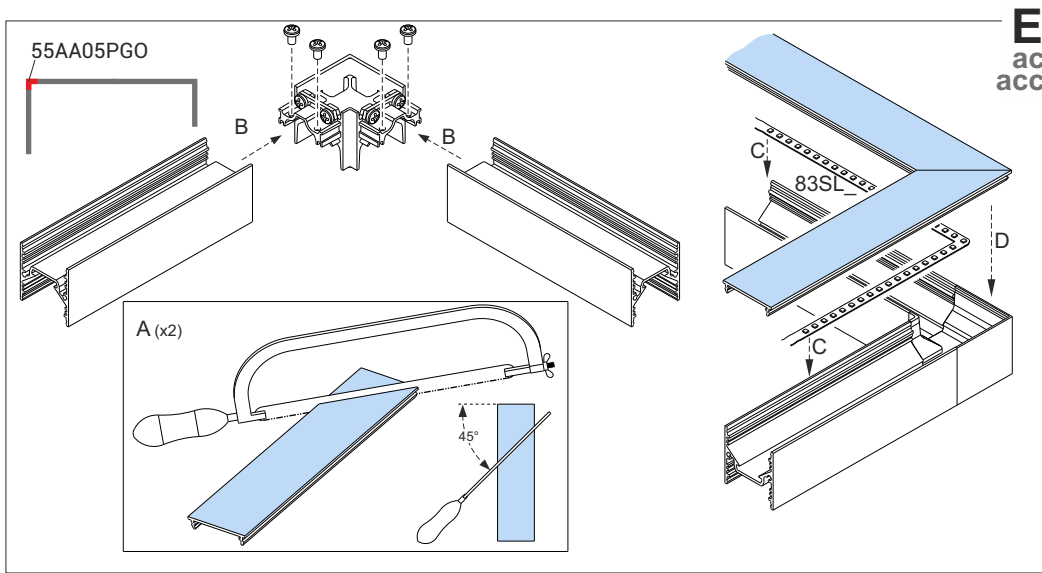

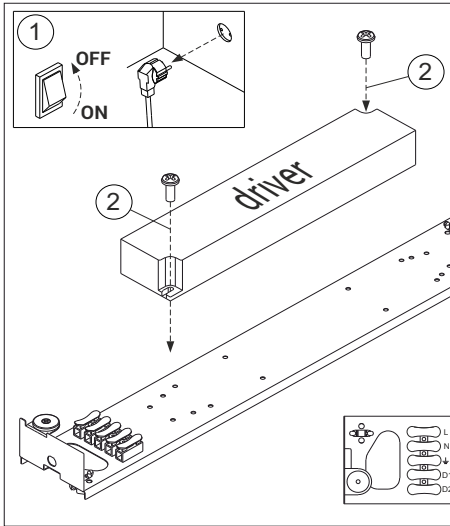

55AA16

ENDO rosone di alimentazione
power supply box

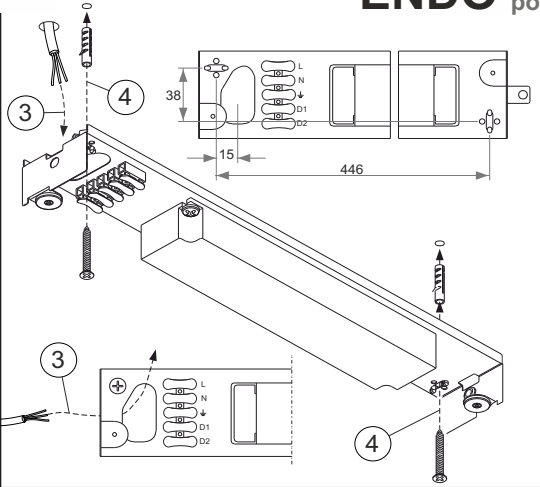

55AA16R

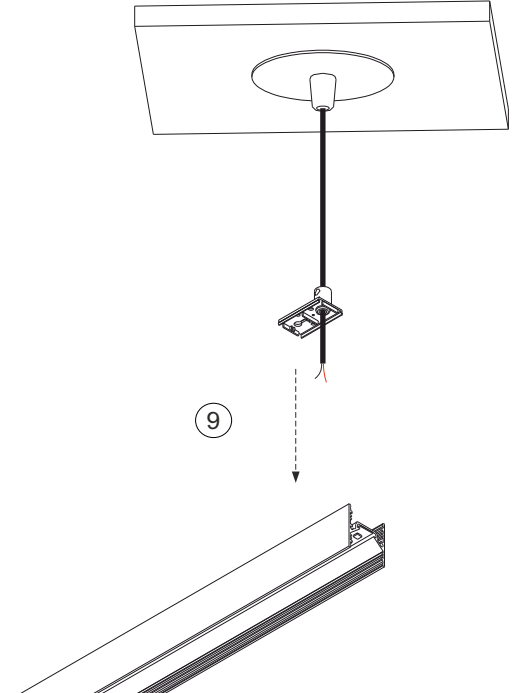
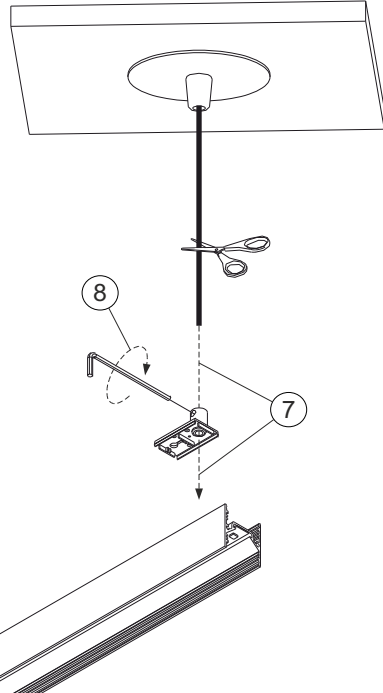
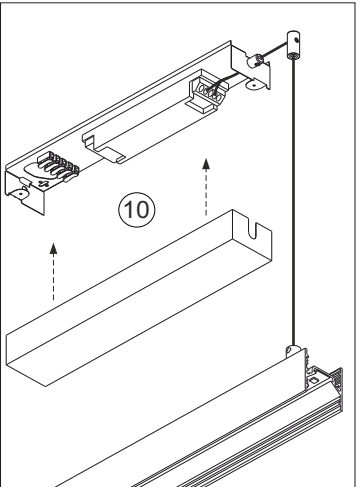
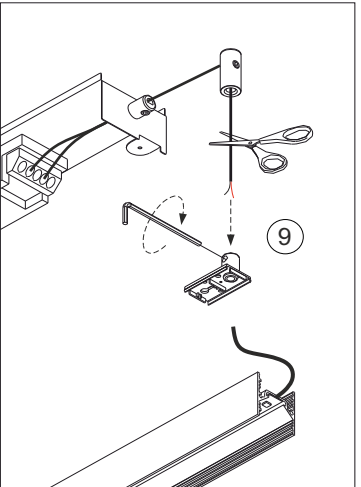
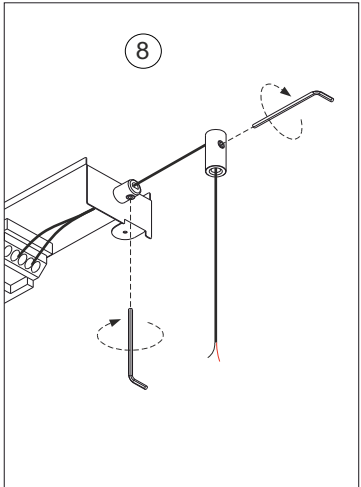
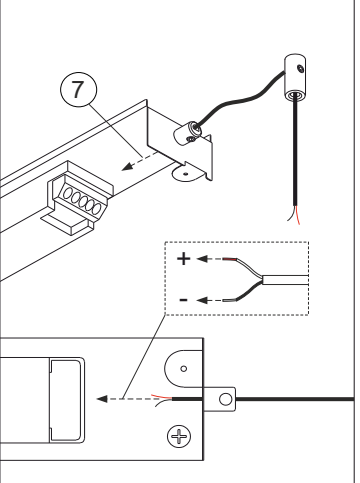
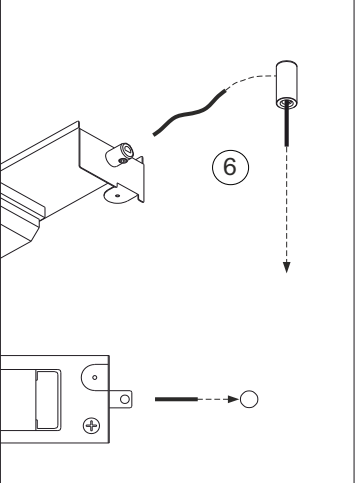
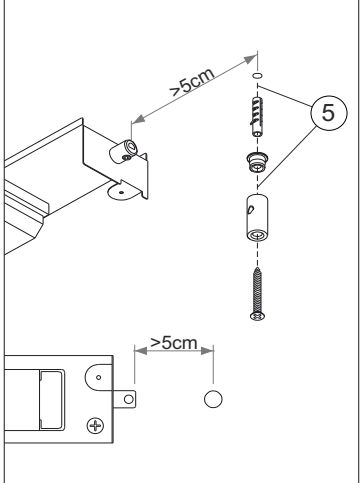
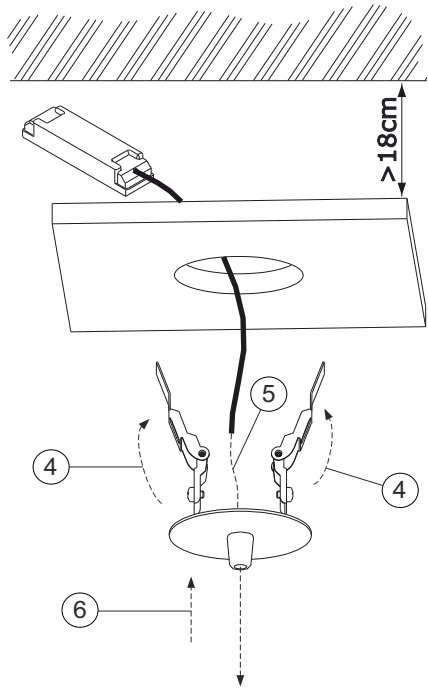
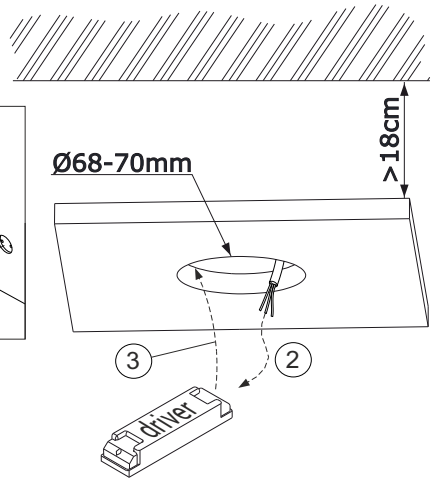
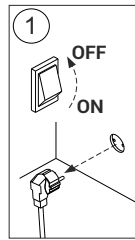

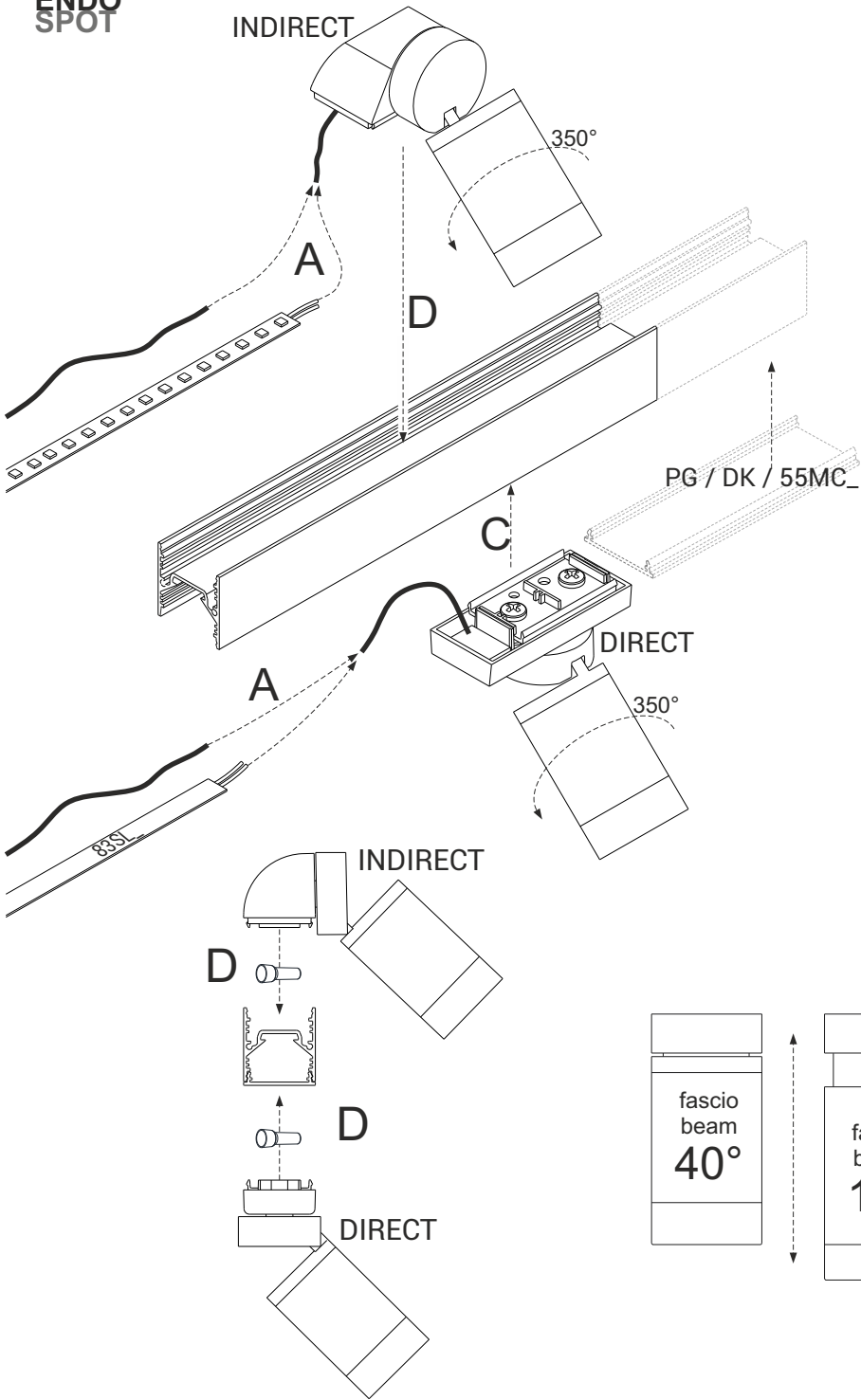

wirings - cablaggi

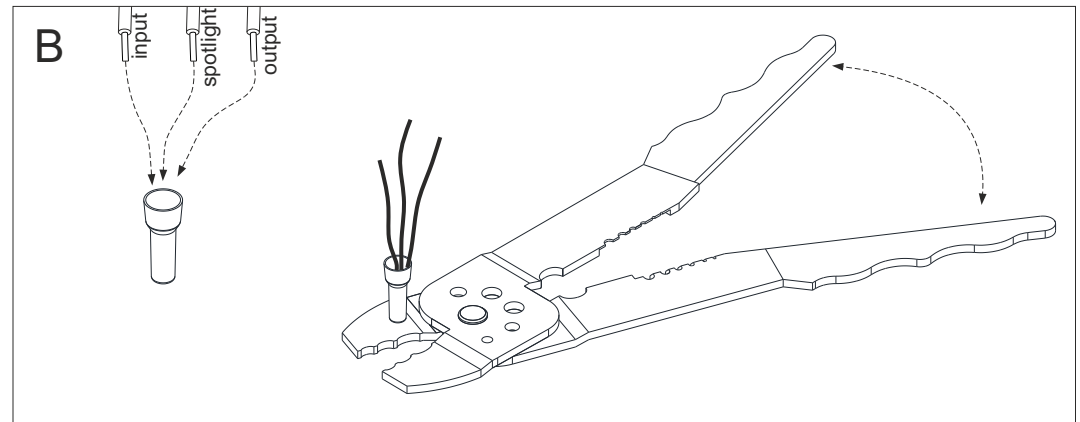
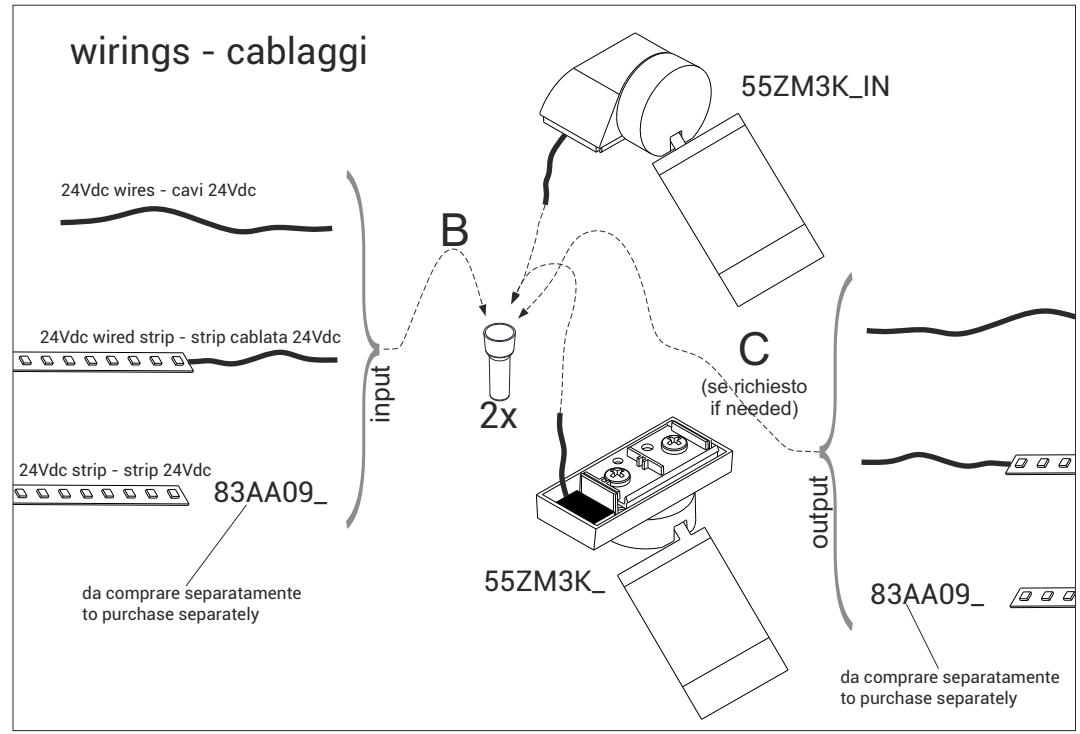

Non guardare la fonte di luce
Do not stare at the light source

CABLAGGIO WIRING

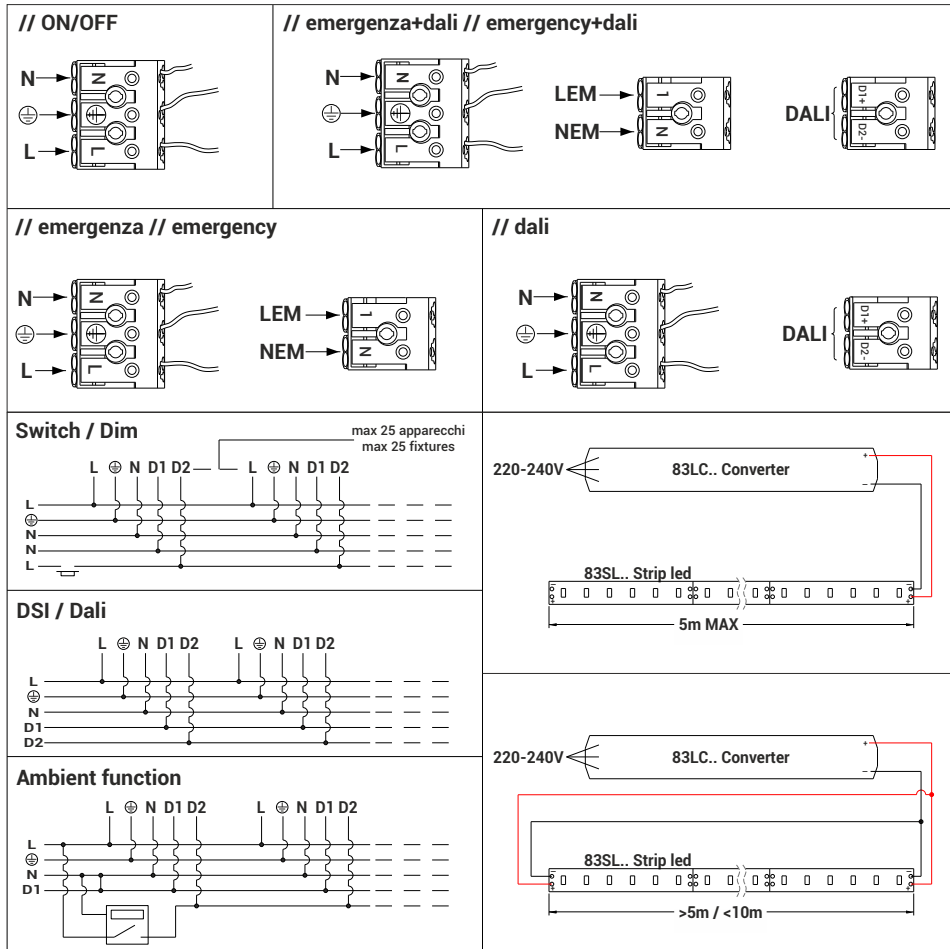

// Avvertenze. La sicurezza dell'apparecchio è garantita solamente con l'uso appropriato delle presenti istruzioni che devono essere lette e conservate. • Togliere tensione di rete prima della sostituzione delle lampade e comunque prima di ogni operazione di manutenzione. • Non coprire l'apparecchio con panni o con quant'altro possa causare un eccessivo surriscaldamento. • La nostra azienda declina ogni responsabilità per danni causati da uno scorretto utilizzo o dalla manomissione dell'apparecchio stesso. • Per la sostituzione di componenti usurati rivolgersi a personale qualificato. • L'apparecchio non deve essere smaltito come rifiuto urbano. Deve essere soggetto a raccolta separata per evitare danni all'ambiente nel rispetto della direttiva 2002/96 e delle leggi nazionali per lo smaltimento del prodotto a fine vita. Il mancato rispetto di quanto sopra è sanzionato dalla Legge. • Si prega di informarsi in merito al sistema locale di raccolta differenziata per i prodotti elettrici ed elettronici.

// Warning. The safety of the fixture is guaranteed only under the correct use of the present instructions, which have to be read and kept. • Turn off the net voltage before the replacement of the lamp and however before any maintenance action. • Do not cover the fixture with clothes or something else which could cause an excessive overheating. • Our company declines all responsibility for damages caused by an incorrect use or by the tampering of fixture itself. • For replacement of worn out components please address to the skilled staff. • The fixture could not be disposed as urban waste. It must be subject o separate waste collection to avoid environmental damage in compliance with directive 2002/96 and national laws for the disposal of product at the end of its working life. The non-compliance of the above mentioned directive will be sanctioned by Law. • We ask you to kindly get information about local separate waste collection system for electric and electronic products.

ISNDCI

ENDO CI

Profilo per incasso frameless
Profile for frameless recessed installation

// Istruzioni per il montaggio // Assembly instructions

- Emissione diretta/indiretta
Direct / Indirect emission
- UGR<22; <16
- IP40, Ip65
- 2700K/3000K/3500K/4000K
5000K / TW / RGBW / DTW
- >100lm/W
- CRI>90
- Eye safety: RGO/RG1
- Mac Adams 3
- L80/B10>50.000h
- EEA Conformity
- Energy class
- 5 years warranty

220-240V AC 50-60Hz; CLASSE/CLASS I

ATTENZIONE! Rischio fotobiologico: gruppo di rischio 1
CAUTION! Photobiological safety: risk group 1

MADE IN ITALY

Attenzione: questo foglio contiene informazioni e suggerimenti importanti. Si prega di leggerlo per intero prima di procedere con l'installazione degli apparecchi.

Attention: this paper contains important info and tips. Please read the full paper before to proceed with installation.



Attenzione: prima di procedere con ciascuna delle seguenti operazioni, togliere la tensione di rete ed utilizzare i guanti in dotazione.

Attention: before proceeding with each of the following operations, switch off the power supply at the consumer unit. Use the gloves supplied.



Attenzione: NON ADATTO ALL'INSTALLAZIONE ALL'ESTERNO
Attention: NOT SUITABLE FOR OUTDOOR APPLICATION

2009/125/CE - Energy-related-Products (ErP)

I	- classe di efficienza energetica LED	3000K
EN	- LED energy efficiency class	
DE	- LED Energieeffizienzklassen	
FR	- classes d'efficacité énergétique LED	
ES	- clase energética LED	4000K
PT	- classe de eficiência energética LED	
NL	- LED energie-efficiëntieklassen	

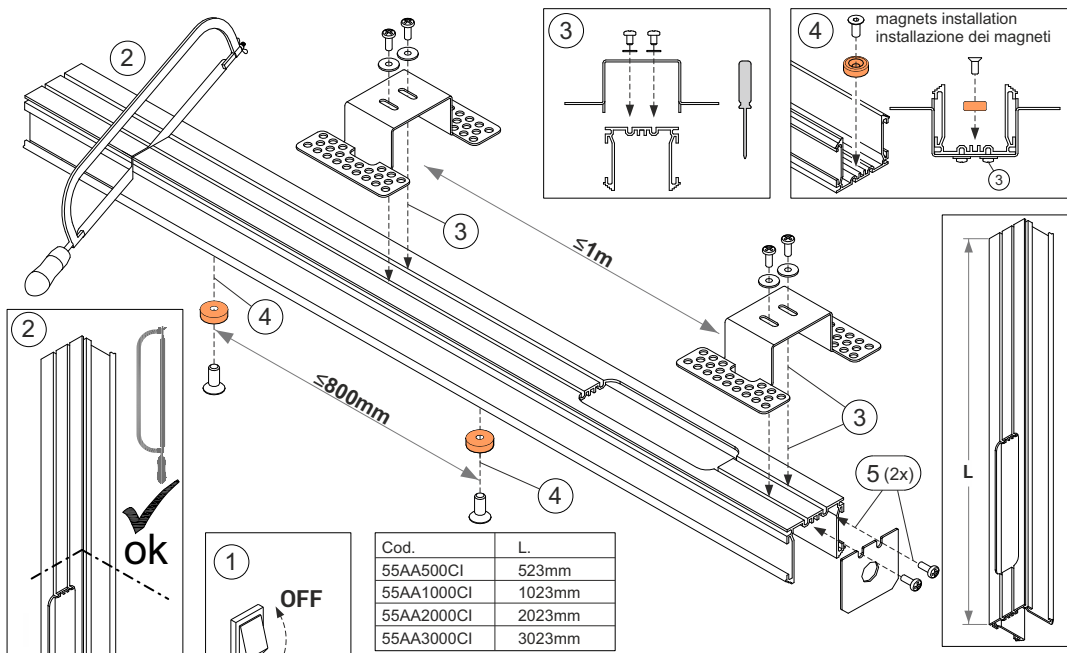

Cod.	L.
55AA500CI	523mm
55AA1000CI	1023mm
55AA2000CI	2023mm
55AA3000CI	3023mm

